

SURVIVABILITY OF CARBON NANOTUBES DURING ARC WELDING

PANCHENKO Oleg¹, IVANOV Sergei¹, KOL'TSOVA Tatyana¹, MICHAÏLOV Vesselin²

¹Peter the Great Saint-Petersburg Polytechnic University, St. Petersburg, Russian Federation

²Brandenburg University of Technology, Cottbus, Germany, EU

Abstract

The behaviour of added to Al-Mg alloy multi-walled carbon nanotubes (CNT) during fusion arc welding was studied. CNTs were added into gap between two Al-Mg alloy sheets which were welded with tungsten inert gas arc welding process (TIG). Welded specimen was fractured using 3-points bending test. Longitudinal section of the welded joint fracture was investigated with scanning electron microscopy and X-ray photoelectron spectroscopy. Evidences of CNT survival, poor CNT wetting by Al-Mg liquid alloy and degradation during arc welding process were found. Displacement of CNTs through liquid metal and CNTs degradation products were studied. Study has shown CNTs emerge process during welding. Magnesium carbonate, aluminium carbide and carbonyl group were found as main degradation products. It was found that composition of degradation products in different parts of weld metal is different. That difference may be caused by inhomogeneity of temperature field and oxygen access to liquid weld metal.

Keywords: Carbon nanotubes, aluminium matrix composites, arc welding

1. INTRODUCTION

Properties of materials depend not only on chemical composition but also on lattice structure and allotropic modification and there are many materials which have different properties depending on crystal lattice structure or allotropic modification [1, 2]. Carbon has several modifications which can be used in development of reinforced materials. For example, carbon nanotubes (CNT) are used to reinforce aluminium matrix [3]. Such metal-matrix composites can give strength improvement up to two times and more [4, 5]. Joining technology of such material is of practical interest. There are a number of publications on usage of friction stir processing for CNT-aluminium composite joining and introduction of CNTs into metal matrix [6 - 8]. Fattahi et al. presented arc welding rods made of aluminium with addition of CNT or graphene nanosheets and found weld metal mechanical properties improvement [9, 10].

Behaviour of CNTs during fusion welding of commercially used aluminium alloys is not studied yet. Purpose of this work is to study CNTs survivability, chemical stability in molten pool during arc welding and distribution of CNTs in solidified Al-Mg alloyed metal.

2. EXPERIMENTAL APPROACH

2.1. Materials

For investigation purposes commercially available multi-walled carbon nanotubes and aluminium alloy 5083 (**Table 1**) were used.

Table 1 Chemical composition of 5083 aluminium alloy

Elements	Si	Fe	Cu	Mn	Mg	Zn	Ti	Cr	Al
Present, %	0.4	0.4	0.1	0.4-1.0	4.0-4.9	0.25	0.15	0.05-0.25	Balance

2.2. Methodology

Due to problems with CNTs detection special designed specimen was developed (**Figure 1**). To decrease radius of CNTs detection, CNTs were put onto one of the plates ledge in two regions. To avoid CNTs blowing off by shielding gas plates were set in butt joint position and tack welded on the edges. Joining procedure was chosen to avoid active processes as much as possible during fusion. Welding was done with tungsten inert gas process without filler material with use of commercially available equipment. **Table 2** presents welding parameters. Welded specimen (**Figure 2**) was fractured by 3 points banding see **Figure 3**.

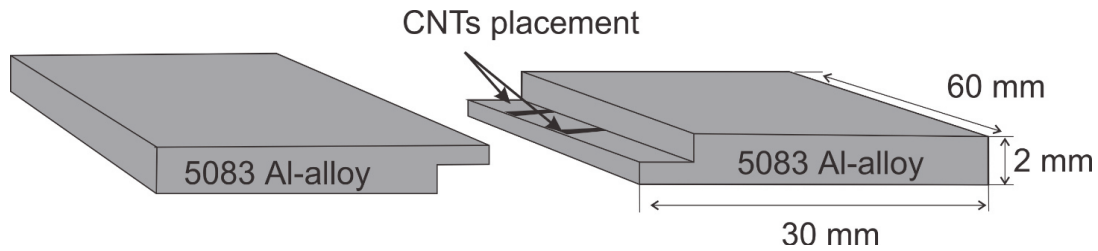

Figure 1 Schematic representation of special designed specimen

Table 2 Welding parameters

Parameter	Value
Current, (A)	80 (Alternative Current)
Voltage, (V)	18-20
Welding speed, (mm/s)	2.5
Shielding gas rate, (l/min)	12 (100% Argon)



Figure 2 Welded specimen top view (arrows pointing on CNTs placement)

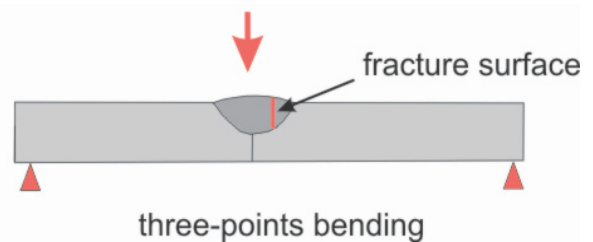

Figure 3 Schematic representation of 3 point bending setup

CNTs distribution and phase composition along the fractured surface was studied by scanning electron microscopy (SEM) on a Tescan Mira 3 microscope and X-ray photoelectron spectroscopy (XPS) on Thermo Scientific K-alpha spectrometer.

3. RESULTS AND DISCUSSION

Using SEM CNTs were found on the fractured surface near the top side of the specimen (**Figure 4, 5**). At least not all of the added CNTs degraded during welding and part of them was displaced from ledge to upper surface. Also poor wetting of CNTs with liquid Al-Mg-alloy was observed.

XPS analysis was done in four points of fractured surface (**Figure 5**). Atomic concentrations of aluminium, carbon and oxygen varies through metal depth (**Figure 6**). It can be seen that carbon content sharply increase near the top surface of the weld (points 1 and 2). It can be explained by the difference in density between CNTs and liquid aluminium. During welding CNTs emerge in liquid aluminum due to CNTs density ($\approx 1.8 \text{ g cm}^{-3}$) much lower than aluminum density (2.7 g cm^{-3}). Agglomeration of CNTs in weld metal leads to inhomogeneity of local mechanical properties of welded joint. Accumulation of CNTs near the top surface of weld and their poor interfacial bonding with matrix may considerably reduce mechanical properties in this place.

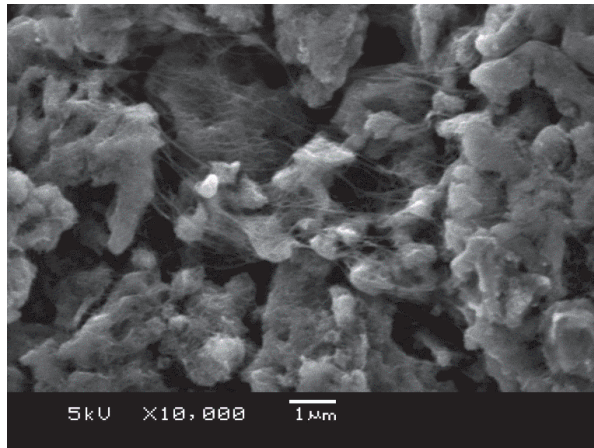

Figure 4 SEM image of fractured surface upper part

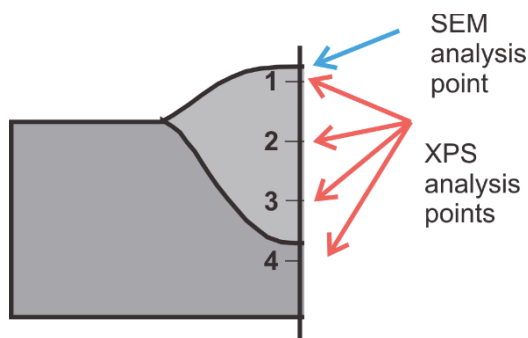

Figure 5 SEM and XPS analysis positions

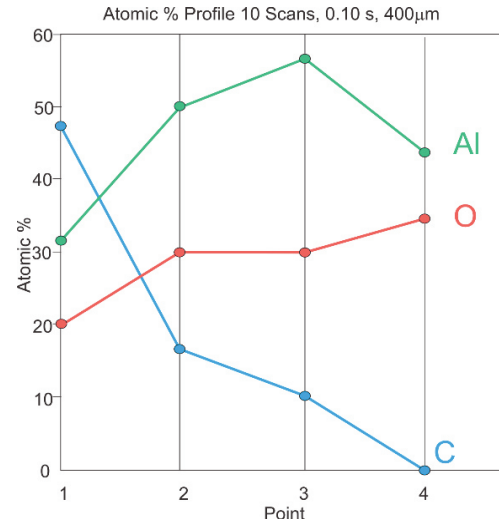

Figure 6 Atomic concentrations of aluminium, carbon and oxygen in four analysed points

Existence of CNTs detected in upper part of weld by SEM doesn't mean absence of CNT degradation. XPS results (**Figure 7**) show new formed bindings of carbon comparing to pure CNT XPS spectra [11]. With usage of the Thermo Scientific K-alpha spectrometer data base CNT degradation products were defined as Me-CO₃, C=O, Me-C [11]. Differences in products of CNTs degradation trough weld depth mainly are caused by inhomogeneity of temperature field during arc welding and probably by access of oxygen.

Aluminium carbides formations were observed in several papers with binding energy near 282 eV and Me-C is aluminium carbide Al₄C₃ (**Figure 7**) [3]. Absence of carbides in point 1 and their formation in depth points 2,

3 can be explained by oxygen access and decreasing of temperature from point 1 to 3 (**Figure 5, 7**). Carbides concentration increases from top to bottom of weld metal (**Figure 7**).

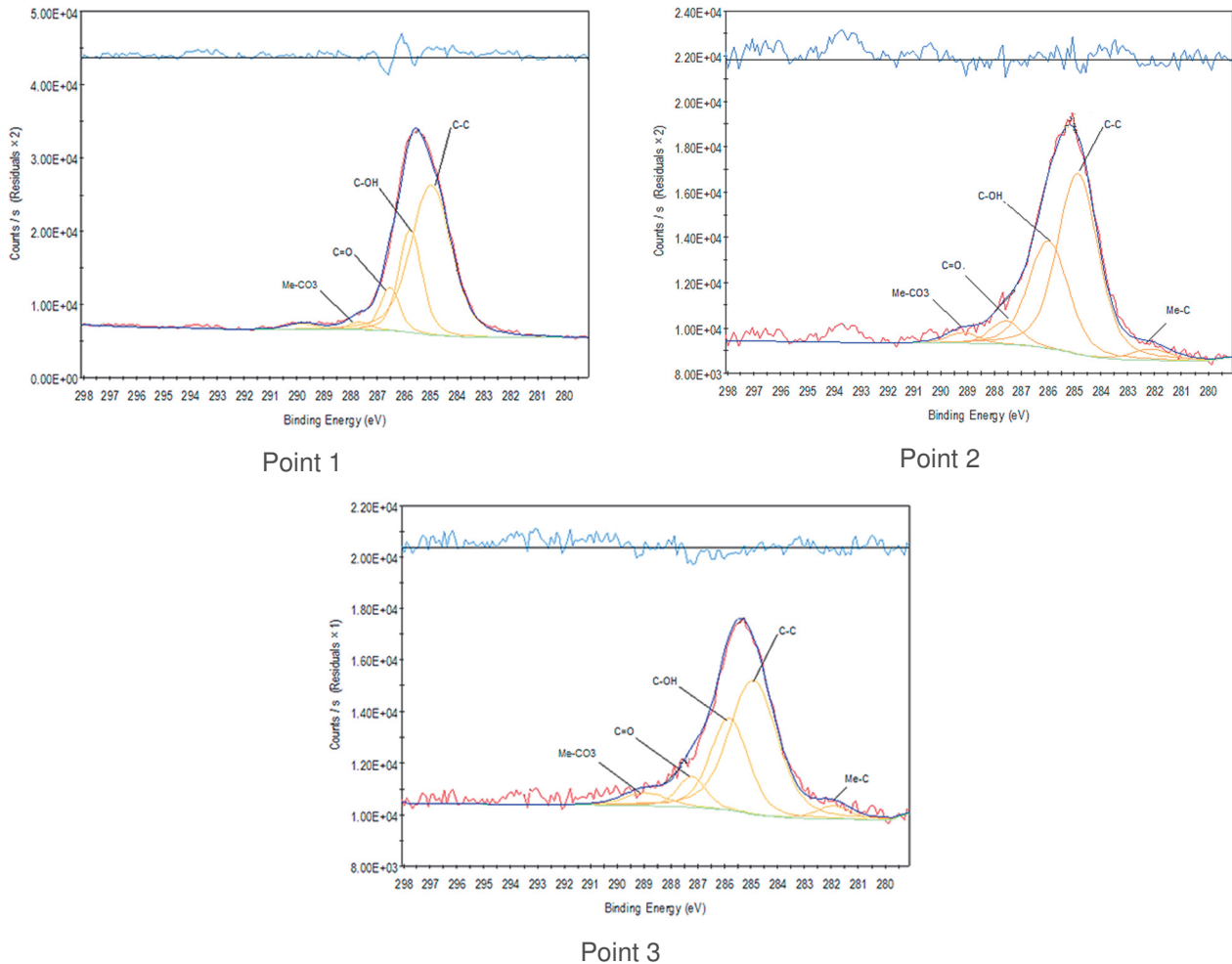

Figure 7 Carbon XPS spectra for three analysed points

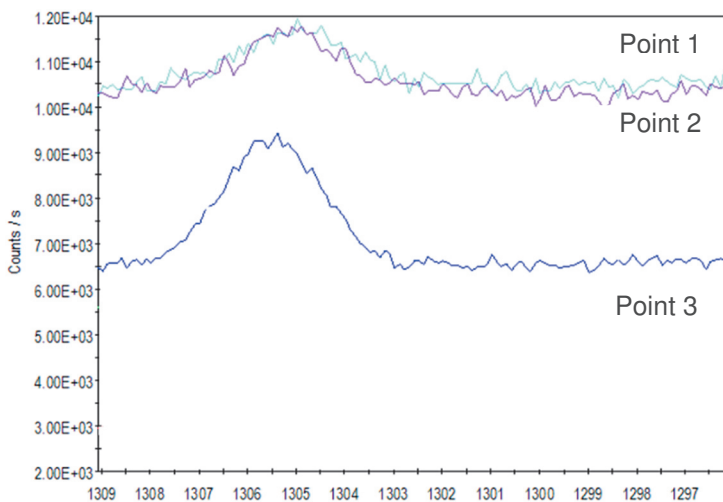

Figure 8 XPS spectra of three points at near binding energy of 1305 eV

According to Thermo Scientific K-alpha spectrometer manufacturer data magnesium carbonate ($MgCO_3$) binding energy is 1305 eV [11]. XPS spectra of three investigated points at this energy level have pikes (**Figure 8**). It means that part of CNTs turns to magnesium carbonate. Similarly with carbides magnesium carbonate formation depends on temperature and differs through weld depth (**Figure 7, 8**).

One of the main factors affecting chemical degradation of CNTs during welding is a dwell time of CNTs in molten pool. Reduction of dwell time by the increasing welding speed or by decreasing of heat input may lead to reduction of chemical degradation of CNTs.

4. CONCLUSIONS

CNTs are partially degraded during arc welding. Survived CNTs emerges to surface of molten weld metal during welding. In solidified weld metal CNTs maximum concentration is located in upper part of weld. Results of SEM indicate poor CNT wetting by liquid Al-Mg-alloy. Agglomeration of CNTs in weld metal leads to inhomogeneity of local mechanical properties of welded joint.

Carbides, carbonates and carbonyl group are main products of CNTs degradation. The use of Al-Mg matrix for arc welding leads to formation of $MgCO_3$ and Al_4C_3 in weld metal. Location of these products varies with temperature field and oxygen access during welding. Carbides and carbonates concentration increases from top to the bottom of weld metal. The main factor affecting chemical degradation of CNTs during welding is a dwell time of CNTs in molten pool. Reduction of dwell time by the increasing welding speed or by decreasing of heat input may lead to reduction of chemical degradation of CNTs.

ACKNOWLEDGEMENTS

The research has been performed at the Peter the Great St. Petersburg Polytechnic University under the contract № 14.Z50.31.0018 with the Ministry of Education and Science of the Russian Federation.

REFERENCES

- [1] VASILYEVA, E., NASIBULIN, A.G., MAXIMOV, M., TOLOCHKO, O., SACHDEV, A., XIAO, X. Synthesis of tungsten diselenide nanoparticles by chemical vapor condensation method. *Medziagotyra*, 2015, vol. 21, issue 3, pp. 339- 342.
- [2] LEBEDEV, B.V., TSVETKOVA, L. YA., ZHOGOVA, K.B. Thermodynamics of allotropic modifications of carbon: Synthetic diamond, graphite, fullerene C_{60} and carbyne. *Thermochimica Acta*, 1997, vol. 229, issue 1-2, pp. 127-131.
- [3] KOL'TSOVA, T.S., SHAKHOV, F.M., VOZNYAKOVSKII, A.A., LYASHKOV, A.I., TOLOCHKO, O.V, NASIBULIN, A.G., RUDSKOI, A.I., MICHAILOV, V.G. Fabrication of a compact aluminum -carbon nanofiber material by hot pressing. *Technical Physics*, 2014, vol. 59, no. 11, pp. 1626-1630.
- [4] CHOI, H.J., SHIN, J.H., BAE, D.H. Grain size effect on the strengthening behavior of aluminum-based composites containing multi-walled carbon nanotubes. *Composites Science and Technology*, 2011, vol. 71, pp. 1699-1705.
- [5] CHOI, MIN, B.H., H.J., SHIN, J.H., BAE, D.H. Strengthening in nanostructured 2024 aluminum alloy and its composites containing carbon nanotubes. *Composites: Part A*, 2011, no. 42, pp. 1438-1444.
- [6] LIU, Q., KE, L., LIU, F., HUANG, C., XING, L. Microstructure and mechanical properties of multi-walled carbon nanotubes reinforced aluminum matrix composites fabricated by friction stir processing. *Materials and Design*, 2013, no. 45, pp. 343-348.
- [7] IZADI, H., GERLICH, A. Distribution and stability of carbon nanotubes during multi-pass friction stir processing of carbon nanotube/aluminum composites. *Carbon*, 2012, no. 50, pp. 4744-4749.
- [8] JOHANNES, L.B., YOWELL, L.L., SOSA, E., AREPALLI, S., MISHRA, R.S. Survivability of single-walled carbon nanotubes during friction stir processing. *Nanotechnology*, 2006, no.17, pp. 3081-3084.
- [9] FATTAHI, M., NABHANI, N, RESHIDKHANI, E., FATTAHI, Y., AKHAVAN, S. ARABIAN, N. A new technique for the strengthening of aluminum tungsten inert gas weld metals: Using carbon nanotube/aluminum composite as a filler metal. *Micron*, 2013, no. 54-55, pp. 28-35.
- [10] FATTAHI, M., GHOLAMI, A.R., EYNALVANDPOUR, A., AHMADI, E., FATTAHI, Y., AKHAVAN, S. Improved microstructure and mechanical properties in gas tungsten arc welded aluminum joints by using grapheme nanosheets/aluminum composite filler wires. *Micron*, 2014, no.64, pp. 20-27.
- [11] XPS Thermo SCIENTIFIC K-ALPHA knowledge base. Web-cite <http://xpssimplified.com/>