

## ELECTROMAGNETIC FORMING OF THIN-WALLED TUBES INTRODUCTION

MORAVEC Ján

*University of Žilina, Faculty of Mechanical Engineering, Department of Technological Engineering, Žilina, Slovakia, EU, [jan.moravec@fstroj.uniza.sk](mailto:jan.moravec@fstroj.uniza.sk)*

### Abstract

This contribution deals with an unconventional way of connection of steel pipes with a thin wall. In the introduction, it is described by one of the methods of electromagnetic forming tubes. The essence of the phenomenon is the induction. Through the coil will lose its accumulated energy, resulting in a repulsive power that causes strain times. Below are described the theoretical conditions of the process and the three possible transition phenomenon in electromagnetic circuits. For the following experiments have proved to be a suitable condition when it is dampened by the current at the limit aperiodicity. The experimental section, deals with the real structural solution of forming equipment for electromagnetic forming tubes. According to equation (1) as referred to in the text of the contribution was determined by the number of turns of the coil. With this coil will carry out experimental work, thus linking the two tubes. The images in the text of the contribution of the entire forming process illustrate. In experimental verification, it was found that an important point is the length of the associated parts. Of great importance, in particular, the thickness of the walls of the pipe. Decreasing the thickness of the walls is in direct dependence with increasing diameter of the hole, or the coil may have higher parameters, as shall be determined by calculation, which is but one of the important conditions for the success of the process after making experiments in the connection parts.

**Keywords:** Magnetism, sheet metal forming, tubes, samples

### 1. INTRODUCTION

Technology of forming has held a prominent place in engineering for several decades. The main advantage of forming is considerable savings in materials, which appear to be highly appropriate and adequate considering the current pressure on greening the production (in general, and worldwide). An unquestionable advantage of forming is its relatively easy process automation. The great significance of forming technology is also in the fact that it allows for a substantial increase in labour productivity, which is reflected in particular in the shortening of the cycle of production and reduction of labour intensity. Application of new knowledge in the production and the use of the technology advantages depend also on the proper construction of forming tools. Relatively higher prices of forming tools, when compared to chip machining tools, impedes penetration of forming technology into piece and small series production. For a long time, experts have been looking for ways to introduce forming technology into this realm. It involves the application of new procedures, consisting in particular of using the knowledge of physics that is a huge and solid source of ideas. Forming in this case mainly takes place in the so-called non-fixed tools. It encompasses machine tools that involve new design solutions where full-metal tools are not needed. This results in minimised production costs and shorter preparation times of the production [1 - 5].

This paper describes one of the non-conventional technologies of forming. The general question is whether it is possible to replace the usual way of forming with another, i.e. a non-conventional method, using magnetisation processes. The term "magnetisation process" generally includes any change in the magnetic state of the substance. In a stricter sense, magnetisation processes usually include changes in the magnetic state induced by the processes in the domain structure of ferromagnetic or ferrimagnetic materials, in particular due to domain walls shift and magnetic polarisation vector rotation. First, the following paragraph introduces theoretical knowledge, then we describe a laboratory design solution for a thin-walled tube forming tool in the

elastic deformation domain, where it is possible to combine tubes into a single whole [6 - 9].

## 2. APPLICATION OF ELECTROMAGNETISM

The essence of electromagnetism is induction. Electromagnetic field must be generated around the components of the conductor to be shaped (formed). We have to make a coil through which the energy accumulated in a set of capacitors can be discharged. This generates repulsive force between the coil and the component - conductor, which causes deformation pulse. The resulting effect depends on the density of vector lines of the electromagnetic field flow. **Figure 1** schematically shows tube forming.

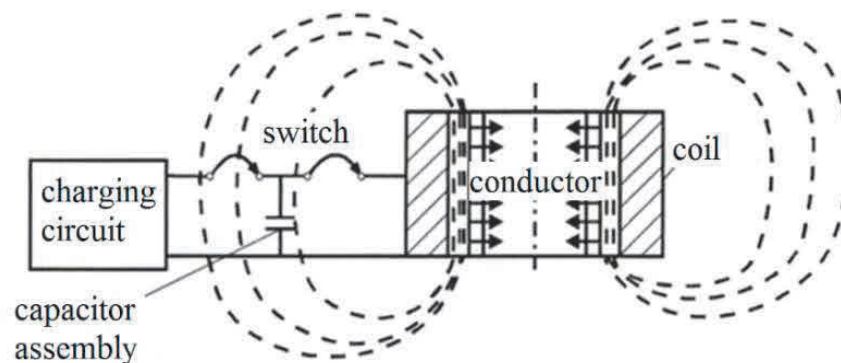

**Figure 1** Scheme of an electromagnetic method used in tube forming

Conventional devices operate with a voltage of 8 - 15 kV, and energy of 12 - 20 kJ. The discharge time is four to ten seconds. The forming pressure is usually 3500 - 5000 MPa.

The method is suitable for tube forming (even extrusion of rounded threads), for pulling and trimming of sheet metal to a thickness of 2 mm, for connecting cable loops and conductors, for connecting non-metallic materials with metallic ones, and for relief decoration on sheet metal surfaces. The material to be formed must have a high electrical conductivity - the maximum is 10 % lower than the conductivity of copper. Forming material with lower conductivity is possible only after it has been copper-plated.

High pulse forces act on the component as well as on the coil. Therefore, coils are made in two types:

- 1) continuous, pre-stressed, insulated with synthetic resin-glass fibre, coated, made of Be and Cu,
- 2) temporary coils that are destroyed at each work run.

The method enables forming even the materials that have been difficult to be formed so far. These materials achieve more reshaping, which eliminates the additional machining and annealing. Maintenance is inexpensive because the device has no moving parts. [10 - 14]

## 3. THEORETICAL KNOWLEDGE

### 3.1. Transient phenomena in electrical circuits

It is necessary to examine the progress of current  $i(t)$  in a series RLC circuit connected to a stationary abrupt voltage  $U$  (**Figure 2**). The above circuit has zero initial conditions, i.e. zero current through the inductor  $i_L(0^-) = 0$ , and zero voltage on the capacitor  $u_C(0^-) = 0$ . After the transient phenomenon aftermath the circuit current will be zero, the capacitor voltage will be  $U$ .

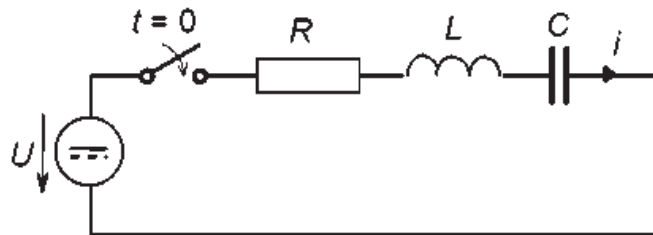

**Figure 2** Examined series *RLC* circuit

The shape of the current time course after turning on the switch depends on the values of parameters *R*, *L*, *C*. There are three cases detailed below:

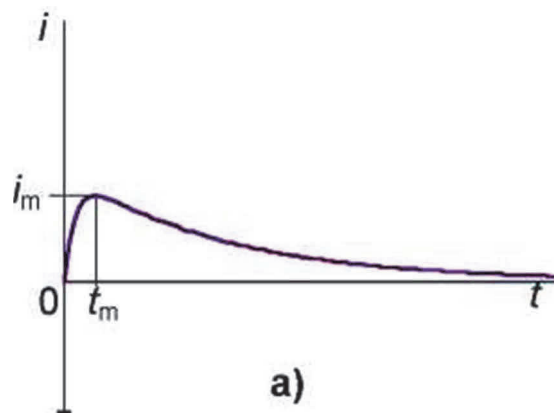

$$R > 2 \cdot \sqrt{\frac{L}{C}}$$

- the current is at time  $t \geq 0$ .

$$i(t) = \frac{U}{L\sqrt{D}} \cdot e^{-\frac{R}{2L}t} \cdot \sinh(\sqrt{D} \cdot t) \quad \text{where} \quad D = \frac{R^2}{4L^2} - \frac{1}{LC}$$

Here, the current is aperiodically attenuated.

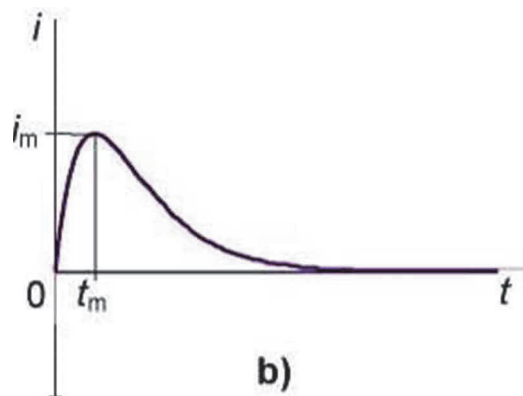

$$R > 2 \cdot \sqrt{\frac{L}{C}} = R_h \quad \text{- where } R_h \text{ is the limit resistance}$$

$$\text{the current at time } t \geq 0 \text{ is: } \quad i(t) = \frac{U}{L} \cdot t \cdot e^{-\frac{R}{2L}t}$$

The current is attenuated at limit aperiodicity.

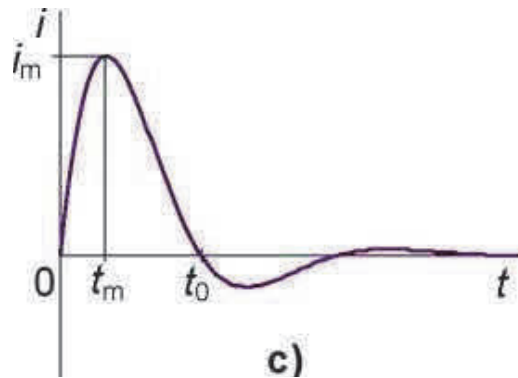

the current at time  $t \geq 0$  is:  $i(t) = \frac{U}{\omega \cdot L} \cdot e^{-\frac{R}{2L}t} \cdot \sin(\omega \cdot t)$ , where angular frequency  $\omega = \sqrt{\frac{1}{LC} - \left(\frac{R}{2L}\right)^2}$   
 The current is aperiodically attenuated with angular frequency  $\omega$ .

The aperiodicity condition is mainly significant as it constitutes the border between two qualitatively different states that differ in their nature of responses. Duration of the transient phenomenon is long in the *a* and *b* cases. Therefore, parameters are designed to be near the limits of periodicity, where the transient phenomenon is shortest. However, this is not desirable in our case.

**4. EXPERIMENTAL WORK**

Description of the Process: A coil is inserted into the tube, and the other part of the tube is prepared for connecting. When the circuit is powered as shown in the scheme in **Figure 3**, there occurs an increase in the diameter of the pipe in which the coil is located. The tubes can be joined while the effect lasts. The principle of the effect is explained in the above paragraph. In this case, there occurs tube wall vibration in the area of return deformation. This effect allows the insertion of one tube into the other, and their connection to create the very joint. In **Figure 4** through **7**, the entire course of the experiment is captured.

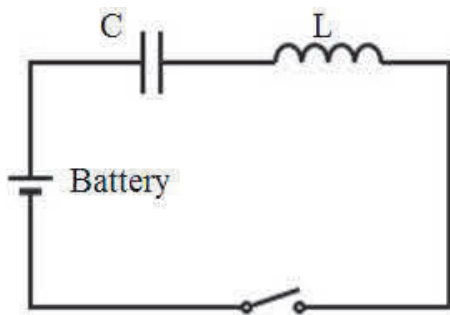

**Figure 3** Examined series RLC circuit



**Figure 4** Samples

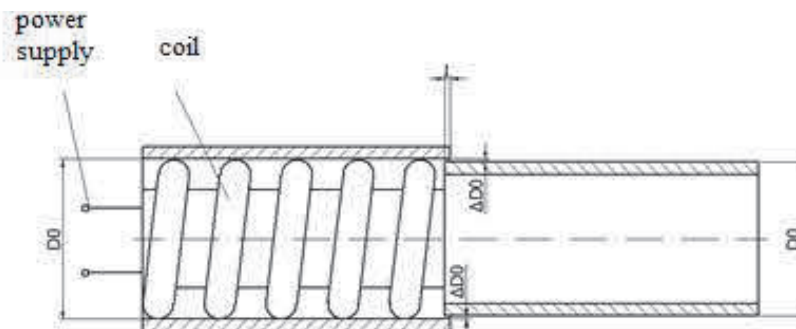

**Figure 5** Scheme of the forming process in an magnetic field



**Figure 6** Experimental equipment for forming



**Figure 7** Samples after joining

Based on scientific literature research, and following my findings from previous experiments, I approached the design and manufacture of a device for electromagnetic tube forming [15]. The material used in the experiments included: tube -  $\varnothing$  45 / 0.6 mm, made of STN 42 5715 steel. The chemical composition of the material is as follows:  $C_{max} = 0.18$  wt. %,  $P_{max} = 0.050$  wt. %,  $S_{max} = 0.050$  wt. %. Tube length: 50 mm. **Figure 3** shows the circuit diagram used in the experiment. As the power source we used a 12V/60Ah car battery Banno Energy Bull K20. We used this power source because of great transforming pulses requiring the so-called hard DC power source - and the car battery reliably accomplished that. We installed a coil on the wires. The number of coil threads ( $N$ ) was determined according to equation (1):

$$N = \frac{B \cdot l}{\mu_0 \cdot \mu_r \cdot I} \quad (1)$$

In samples of:  $B$ - magnetic flux density (T),  $l$  - target spool (mm),  $I$ - current (A)  
 $\mu_0$  -permeability of vacuum ( $\text{Hm}^{-1}$ ),  $\mu_r$ - relative permeability ( $\mu / \mu_0$ ).

The problematic element appeared to be the coil, since it must be greater by at least 30 %. It is similar to explosive forming. A larger diameter equals a larger coil (dimensionally), and a thicker wire. Reality: The insertion was only by a few tenths of mm. This was the result of the coil being weak.

#### 4.1. Findings and limitations:

- The lengths of the parts are important because, using the optimal method, the coil can slide along the tube. This, however, results in the necessity to use long conductors (wires), which in turn causes voltage drop (resistance in conductors).

- An important factor is the wall thickness of the part to be joined. A slope must be created on the part to be connected, which facilitates the process.
- It was shown that decreasing the tube wall thickness and increasing the inner tube diameter are directly related, which means that a coil with a sufficient number of threads (length of wire) can be used, which reliably guarantees a solid joint of the two parts.

## 5. CONCLUSION

Despite the fact that there was no solid connection (joint) of the parts, the experiment showed the way to connect such parts without using additional material (such as in gluing, welding, soldering). The above method can be regarded as suitable in terms of environmental impacts on the surrounding area, as it does not produce any side effects on humans either. That is, this method does not pollute the environment [15].

## REFERENCES

- [1] PSYK, V. RISCH, D. KINSEY, B.L. TEKKAYA, A.E. KLEINER, M. Electromagnetic forming a review. *Journal of Materials Processing Technology*, 2001, Vol. 211, No. 5, pp. 787-829.
- [2] GOLOVASHCHENKO, S., F. Electromagnetic Forming and Joining for Automotive Applications. *High Speed Forming*, 2006, pp. 201-206.
- [3] AREZOODAR, A.R.F. GARZAN, E. EBRAHIMI, H. Effect of various field shapers on magnetic pressure in electromagnetic inward tube forming. *Advances in Fluid Mechanics and Heat & Mass Transfer*, pp. 338-342.
- [4] VANHUNSEL, P. VAN WONTERGHEM, M. DE WAELE, W. FAES, K. Groove design for form fit joints made by electromagnetic pulse clamping. *Sustainable Construction and Design*, 2011, pp. 432-441.
- [5] ZHENGUA, M. et al. Effects of process parameters on warm electromagnetic hybrid forming of magnesium alloy sheets. *Journal of Material Processing Technology*, 2011, Vol. 211, pp. 863-867.
- [6] HAI-PING, Y. CHUN-FANG, L. Effects of coil length on tube compression in electromagnetic forming. *Trans. Nonferrous Met. Soc. China*, 2007, Vol.17, pp. 1270-1275.
- [7] MAIER-KOMOR, P. HOFFMAN, H. OSTERMAIR, M. Cutting of hollow profiles using electromagnetic fields. *Int. J. mater. Form.*, 2001, Vol.3, pp. 203-506.
- [8] KRAUSEL, V. SCHAFFER, R. ENGELBRECHT, I. Gepulste elektromagnetische Felder schneiden hochfest Bleche. *Maschinenmarkt*, 2010, No.4, pp. 26-29.
- [9] EGUIA, I. ZHANG, P. DAEHN, G.S. Improved crimp-joining of aluminium tubes onto mandrels with undulating surfaces. *1<sup>st</sup> international conference on high speed forming*, 2004, Ohio, USA, pp. 161-170.
- [10] WOODWARD, SX. WEDDWLING, CH. DAEHN, G. PSYK, V. Production of low-volume aviation components using disposable electromagnetic actuators. *Journal of Material Processing Technology*, 2011, vol. 211, pp. 886-895.
- [11] SHANG, J. CHENG, V. HATKEVICH, S. DAEHN, G.S. Agile manufacturing of a micro-embossed case by a two-step electromagnetic forming process. *Journal of Materials Processing Technology*, 2007, Vol. 190, pp. 41-50.
- [12] SHANG, J.M.S. *Electromagnetically assisted sheet metal stamping*. 2006, Dissertation thesis, Graduate School of The Ohio State University
- [13] OKOYE, C.N. JIANG, J.H. HU, Z.D. Application of electromagnetic-assisted stamping (EMAS) technique in incremental sheet metal forming, *International Journal of machine Tools and Manufacture*, 2006, Vol. 46, pp. 1248-1252.
- [14] UNGER, J. STIEMER, M. SVENDSEN, B. BLUM, H. Multifid modeling of electromagnetic metal forming process. *Journal of Materials Processing Technology*, 2006, Vol. 177, pp. 270-273.
- [15] MORAVEC, J. *Magnetism in the forming*, 2005, EDIS vyd., ŽU Žilina, 133 p., ISBN-80-8070-385-X (in Slovak)