

INTRODUCTION AND DEFINITION OF LAMINAR FLAWS PROVIDED BY FLAW EVALUATION CODE

HASEGAWA Kunio¹, STRNADEL Bohumir¹, LACROIX Valery²

¹Center of Advanced Innovation Technologies, VSB -Technical University of Ostrava, Czech Republic, EU

²Tractebel Engineering, Brussels, Belgium, EU

Abstract

Delamination or laminar flaws were sometimes detected during manufacturing and/or plant operations. A laminar flaw is a subsurface flaw parallel to the rolling direction of the plate. Definition of the laminar flaw is provided only in the ASME Boiler & Pressure Vessel Code Section XI and API 579/ASME FFS-1 Code. In addition, the both Codes provide different combination rules for multiple laminar flaws.

Besides, a large number of laminar indications were detected in pressure vessels. The observed indications were caused by hydrogen flaking induced during the manufacturing process. The ASME Code Section XI Committees have recently developed a rule that provides a combination methodology for a large number of quasi-laminar flaws.

This paper introduces the definitions and combination rules of laminar flaws defined by the ASME and API 579/ASME FFS-1 Codes, and quasi-laminar flaws newly developed by the ASME Code Case.

Keywords: Laminar flaw, quasi-laminar flaw, subsurface flaw, combination rule, code

1. INTRODUCTION

Delamination or laminar flaws occur by inclusions such as Manganese Sulphur (MnS), hydrogen flakes, etc., in steels at manufacturing. A laminar flaw is a subsurface flaw parallel to the rolling direction of the plate, where the applied stress is typically parallel to the rolling direction. The definition of the laminar flaw is provided only in the ASME Boiler & Pressure Vessel Code Section XI [1] and API 579/ASME FFS-1 Code [2]. In addition, the both Codes provide different combination rules for multiple laminar flaws.

Besides, a large number of laminar indications were detected in nuclear power reactor vessels [3]. The observed indications were caused by hydrogen flaking induced during the manufacturing process. The ASME Code did not previously consider such a large number of laminar flaws and these laminar flaw angles are larger than the angles of the normal laminar flaw definition. The large tilted laminar flaws were named as quasi-laminar flaws. The ASME Code Section XI Committees have recently developed a rule that provides a grouping methodology for a large number of quasi-laminar flaws.

This paper introduces the definitions of laminar and quasi-laminar flaws provided by the ASME Boiler & Pressure Vessel Code and API 579/ASME FFS-1 Code. Furthermore, this paper describes the combination rules for laminar and quasi-laminar flaws for flaw evaluation.

2. DEFINITION OF LAMINAR FLAWS

There are about 14 flaw evaluation codes and standards in the world. Almost all flaws in these codes and standards are considered planar flaws, such as fatigue cracks, stress corrosion cracks, welded defects, etc. Laminar flaws are unique treatment in the codes and standards. This is because a laminar flaw is a subsurface flaw parallel to the rolling direction of the plate, where the applied stress is typically parallel to the rolling direction making them relatively harmless. The definition of the laminar flaw is provided only in the ASME Code Section XI [1] and API 579/ASME FFS-1 [2]. A laminar flaw in the wall thickness t is shown in **Fig. 1**.

In accordance with the ASME Code, if the angle α between the direction parallel to the wall thickness and the axis of laminar flaw is less than 10 degrees, it is judged to be a laminar flaw. If the angle α is less than 20 degrees, the flaw is called a quasi-laminar flaw [4]. The definition in ref. [4] states that planar indications oriented within 20 degrees of a plane parallel to the surface of the component is classified as a quasi-laminar flaw.

In the case of the API 579/ASME FFS-1 Code, if $L_h \leq 0.09$ times the maximum (w_s , w_c), the flaw is a laminar flaw, where L_h is the lamination height, w_s is the lamination dimension in the longitudinal direction and w_c is the lamination dimension in the width direction, as shown in Fig. 1. When $w_s > w_c$, the angle of $L_h/w_s = 0.09$ corresponds to $\alpha = 5.2$ degrees. The maximum slope of the laminar flaw given by the API 579/ASME FFS-1 is almost one half of the angle provided by the ASME Section XI Code.

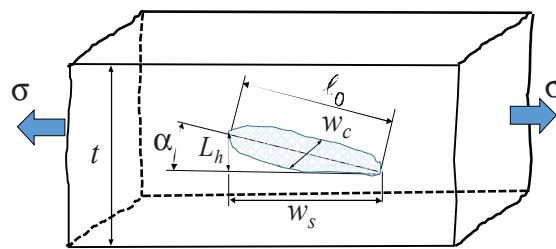

Fig. 1 Definition of a laminar flaw

3. COMBINATION RULE OF MULTIPLE LAMINAR FLAWS

If two laminar flaws are sufficiently close to each other, as shown in Fig. 2, they are combined by combination rule to a single laminar flaw even when the flaw planes are by far spaced. The combination rule given by the ASME Code is expressed as;

$$S \leq 25.4 \text{ mm} \tag{1}$$

where S is the distance measured in the orthogonal principal coordinate system. After flaw combination, the combined laminar flaw is evaluated with lengths of ℓ and W .

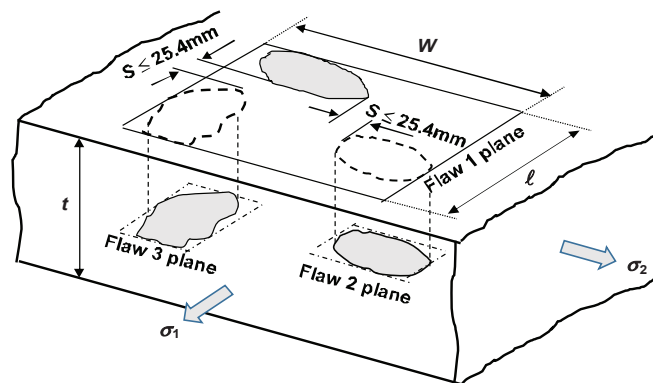

Fig. 2 Combination laminar flaws provided by the ASME Code Section XI.

The API 579/ASME FFS-1 Code also provides a combination rule of laminations. If there are two laminations on the same plane and there is no indication of through thickness cracking, and if the spacing L_s meets,

$$L_s \leq 2t_c \tag{2}$$

then the laminations are combined into a single large lamination, where L_S is the lamination to lamination spacing and t_c is the wall thickness considering metal loss and future corrosion loss, as shown in **Fig. 3**.

If there are two or more laminations at different depths in the wall thickness and the spacing satisfies Eq. (2), the combination of the laminations are evaluated as the method of criterion for local metal loss. The dimensions of the metal loss are w_H , w_S and w_C , where w_H is the damage thickness in the thickness direction, w_S is the length in the longitudinal direction and w_C is the length in the width direction, as shown in **Fig. 3**. In addition, the distance L_W between any edge of the lamination and the nearest weld seam must satisfy $L_W \geq \text{maximum}(2t, 25 \text{ mm})$.

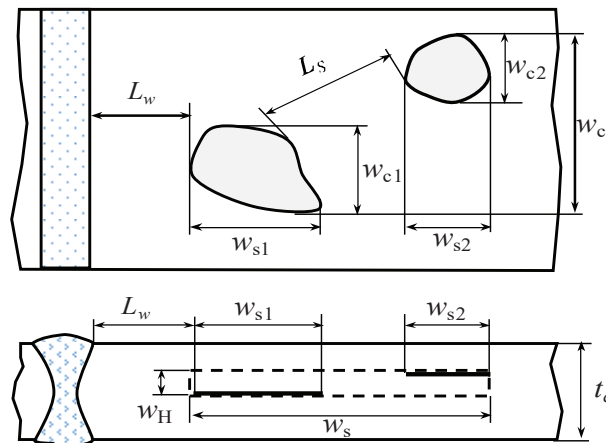

Fig. 3 Combination of laminar flaws provided by the API 579/ASME FFS-1 CODE

4. ALTERNATIVE COMBINATION RULE OF MULTIPLE QUASI-LAMINAR FLAWS

A large number of quasi-laminar indications were detected in specific nuclear power reactor vessels [3]. The observed indications were caused by hydrogen flaking induced during the manufacturing process. The ASME Code did not previously consider such a large number of laminar flaws. The ASME Code committees have recently developed a Code Case N-848 [4] that provides a grouping methodology for a large number of quasi-laminar flaws, as follows.

A continuous indication is defined as a quasi-laminar flaw if the detected area of the flaw is oriented primarily in a single plane and if the plane is oriented within 20 degrees of a plane parallel to the pressure retaining surface of the component. Each quasi-laminar flaw is bounded by the minimum bounding box (rectangular cuboid) that fully contains the area of the flaw.

Fig. 4 shows the bounding boxes of two quasi-laminar flaws. The separation distances between the boxes bounding the flaws are S_1 and S_2 along the direction of axial stress σ_1 and hoop stress σ_2 , and H along the through-wall thickness direction. If the distances S_1 , S_2 and H meet the diagonals of each cuboid as

$$\left. \begin{aligned} S_1 &\leq 2 \text{ minimum of } (D_{11}, D_{12}, D_{21}, D_{22}), \text{ and} \\ S_2 &\leq 2 \text{ minimum of } (D_{11}, D_{12}, D_{21}, D_{22}), \text{ and} \\ H &\leq 0.85 \text{ minimum of } (D_{11}, D_{12}, D_{21}, D_{22}) \end{aligned} \right\} \quad (3)$$

the multiple quasi-laminar flaws are combined into a single flaw. If the boxes are partially or totally overlapping in any one direction, the combination criterion in that direction is met. The combined single flaw is sized by the minimum bounding box that contains the individual boxes. The criteria are also applicable to laminar flaws. After combination of the quasi-laminar flaws, the dimensions of the quasi-laminar flaw are given as:

$$\left. \begin{aligned} l_1 &= l_{11} + S_2 + l_{12}, \\ l_2 &= l_{21} + S_1 + l_{22}, \\ 2d &= 2d_1 + H + 2d_2. \end{aligned} \right\} \quad (4)$$

For the purpose of evaluating fatigue crack growth and flaw acceptability assessment, the bounding box is resolved into two rectangular planar flaws corresponding to the faces of the box normal to the principal stresses. These two planar flaws are treated as surface/subsurface flaws.

The criteria were derived from calculations of interaction of stress intensity factors for inclined flaws. These grouping criteria were developed by two- and three- dimensional X-FEM (extended finite element method) analyses [5, 6].

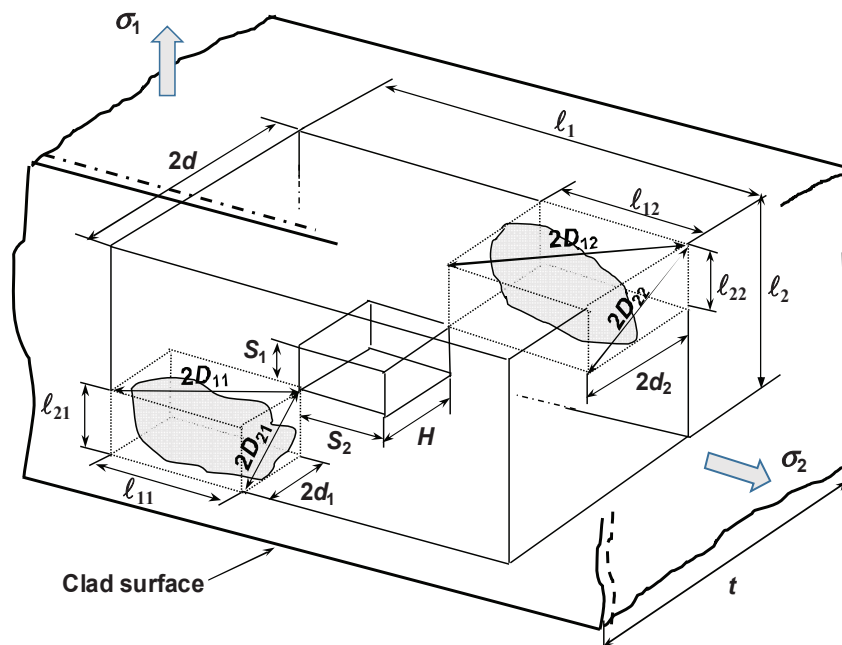

Fig. 4 nBoundig box of combined flaw for multiple quasi-laminar flaws

5. CONCLUSIONS

Laminar flaw is not a popular flaw in flaw evaluation codes. Laminar flaw is evaluated by only the ASME and API 597/ASME FFS-1 Codes. However, the specific definition and combination procedures of these uses are different between two Codes. It is expected that predicted structural integrities of the components including laminar flaws will be different depending on which code is used, although the original flaws are the same. Consensus-based flaw rule is required for harmonizing assurance for the flawed components.

New combination rule for a large number of quasi-laminar indications was successfully developed by the ASME Code based on interaction of stress intensity factors for inclined flaws.

ACKNOWLEDGEMENTS

This paper was created under support of the Project No. LO1203 "Regional Materials Science and Technology Centre - Feasibility Program" funded by Ministry of Education, Youth and Sports of the Czech Republic. The financial support of the Technology Agency of the Czech Republic under grant TA 02011179 is gratefully acknowledged.

REFERENCES

- [1] American Society of Mechanical Engineers, ASME B&PV(Boiler and Pressure Vessel) Code Section XI, Rules for In-service Inspection of Nuclear Power Plant Components, 2013 Edition.
- [2] American Petroleum Institute, API 579-1/ASME FFS-1, Fitness-for-Service, June, 2007.
- [3] Federal Agency for Nuclear Control (FANC), Final report, <http://www.afcn.fgov.be/GED/00000000/3400/3429.pdf>
- [4] American Society of Mechanical Engineers, ASME Code Section XI Code Case N-848, Alternative Characterization Rules for Quasi-Laminar Flaws, 2015.
- [5] Lacroix V., Dulieu P., and COUPLLET D. Alternative Characterization Rules for Quasi-Laminar Flaws, PVP2014-28200, ASME PVP Conference, Anaheim, CA, July, 2014.
- [6] Lacroix V., Dulieu P., and Bogaer, A-S, Alternative Characterization Rules for Quasi-Laminar Flaws Based on 3D X-FEM Calculations, PVP2015-45792, ASME PVP Conference, Boston, MA, July, 2015.